

Installation of Fire Resistant Door Frames

RESPONSIBILITIES OF OTHER TRADES

Greater attention should be paid to building works that may not be considered as an important part of fire protection. The Australian Standard applies to a **fire-resistant doorset**, this includes the door frame.

Poor practice and carelessness could cause fire resistance to be compromised or require costly rectification, indirectly increasing the cost of fire protection to the industry.

- The frame shall be backfilled to meet the requirements of **AS1530.4**
 - AS1530.4** requires the measurement of temperature rise on the fire door frame as well as the fire door itself when subject to the standard fire door test. Consequently, the frame needs to be insulated to ensure it meets the temperature rise requirements
- The frame shall be installed into an approved fire rated wall system.
 - Follow the frame back filling requirements
 - Follow the installation instructions
 - Follow the tested specimen fixing requirements
 - Ensure your frame installer understands their responsibility
- The frame jambs shall be installed plumb and parallel, the head of the frame shall be level and Square. (**Example:2**)
 - The correct installation of a door frame is a critical part of ensuring compliance.
- The frame shall be inwind'. (**Example:1**)
 - Any frame that is out of wind is likely to compromise the fire door installation and may render the fire doorset non-compliant
 - Sight the frame through to make sure it is in wind. This is done by sighting one edge of the door frame through to the opposite edge. As you look through, let your eye wander from top to bottom and check the frame jambs are parallel

AUSTRALIAN STANDARD
1905.1: 2015 SECTION 2
DESIGN REQUIREMENTS

cl.1.1 The essential components of a fire-resistant doorset are the door leaves, frame, hinges, latches and closers. These are the minimum components required to make a fire-resistant doorset that is functional, capable of testing in accordance with AS 1530.4 and capable of meeting the requirements of this Standard. The design criterion for all components of the fire-resistant doorset (whether they are essential or not) is to not adversely affect the fire resistance (i.e. FRL performance) of the fire-rated wall that they are installed in. Therefore, any component added or substituted to a fire-resistant doorset should be of materials and construction capable of maintaining or enhancing the fire performance of the doorset.

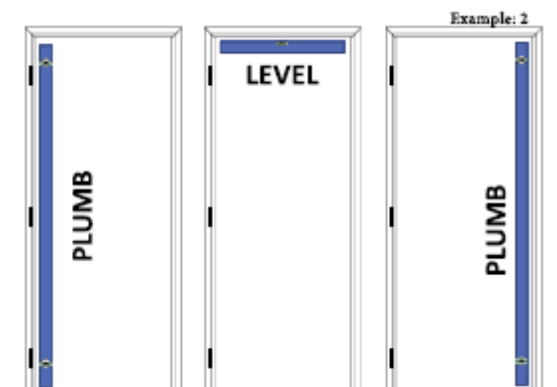
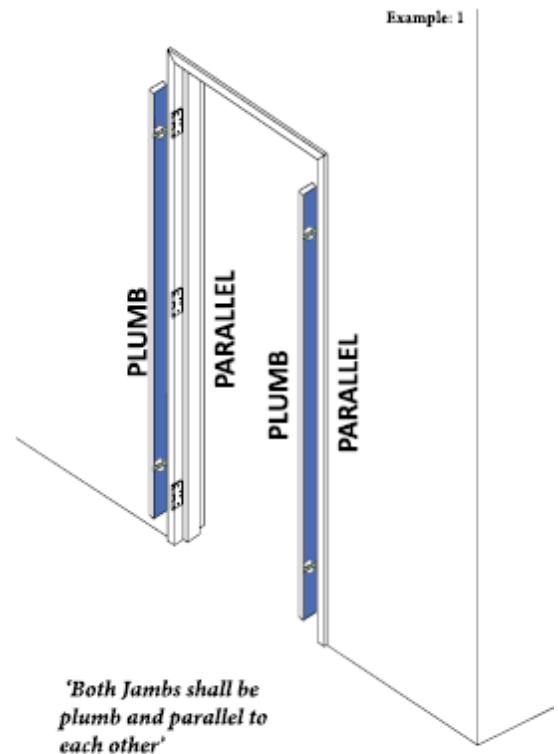

'The frame jambs shall be installed plumb and parallel, the head of the frame shall be level and Square'. IN ALL WALL TYPES.

The Non-Combustible Threshold Around & Under Fire Resistant Doors

RESPONSIBILITIES OF OTHER TRADES

Greater attention should be paid to building works that may not be considered as an important part of fire protection. Poor practice and carelessness could cause the fire resistance to be compromised or require costly rectification, indirectly increasing the cost of fire protection to the industry.

The Non-Combustible Threshold Under a Fire Resistant Doorset

1. The floor surface, either the non-combustible threshold or the floor covering shall be sufficiently flat and level so when a fire resistant doorset is installed, it can operate unhindered and with a compliant clearance when in the closed position.
2. Lifting and levelling the top of fire rated door frames may leave a large gap under the door and frame jamb.
 - Consider the fire resistance required to be compliant
 - Level the floor to enable compliance
3. Any excessive hollows or bumps in the floor that could compromise the fire resistant doorset installation shall be rectified before certification.
 - Level the floor between jambs
 - Level the hollow in the floor
 - Rectify the bump in the floor

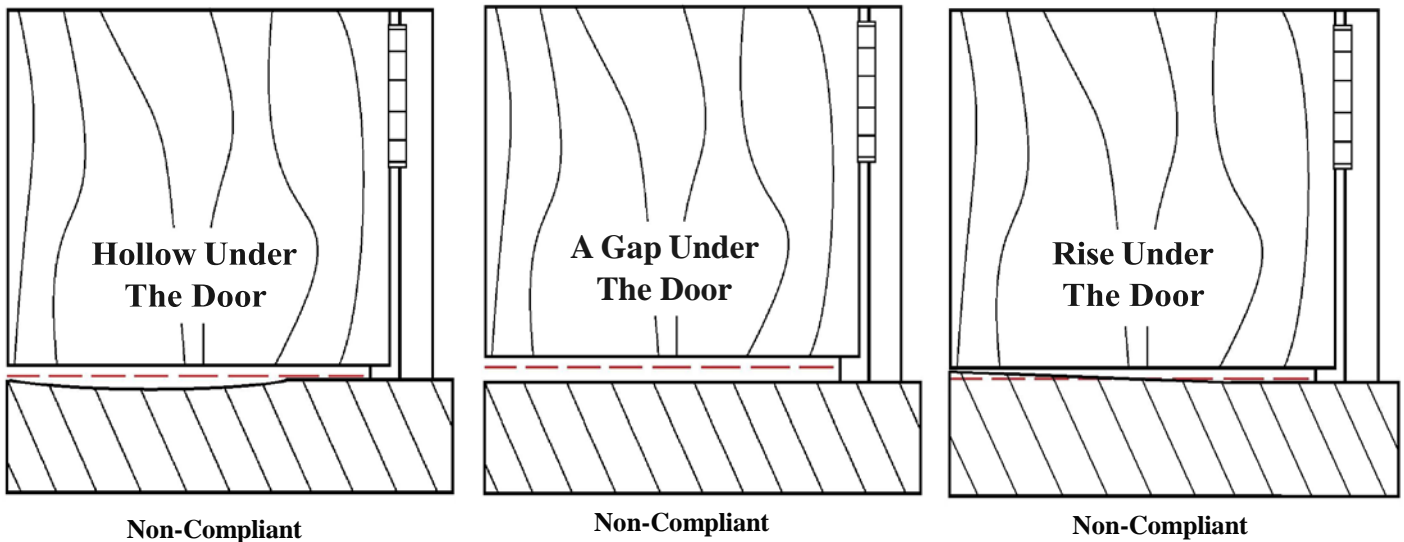

AUSTRALIAN STANDARD

1905.1: 2015 Requires: Section 5
INSTALLATION: Clause 5.5.1
Threshold and floor finish
Clearances between the bottom of
all door leaves and the floor shall
be as follows:

- a) Between the leaf and the top surface of the floor including any floor covering-not less than 3 mm and not more than 10 mm.
- b) Between the leaf and the top of the non-combustible threshold-not more than 25 mm.

NOTE: When the installed doorset is inspected for compliance with Item (b), the clearance should not exceed 25 mm for the purpose of certification unless a note providing information on clearances is made in the evidence of compliance.

The Non-Combustible Threshold Around & Under Fire Resistant Doors

RESPONSIBILITIES OF OTHER TRADES

The Non-Combustible Threshold and floor finish within the door swing zone.

1. The floor surface, either the non-combustible threshold or the floor covering shall be sufficiently flat and level so when a fire resistant doorset is in operation it can operate unhindered without binding on any part of the floor within the door swing zone.
 - Check for any bump or rise in the floor
 - Check for any slope in the floor
 - Uneven floors should be rectified by the trade responsible
2. Trimming the bottom of the door leaf to accommodate uneven floors could render the fire door non-compliant when in the closed position.
 - Determine your options before you proceed

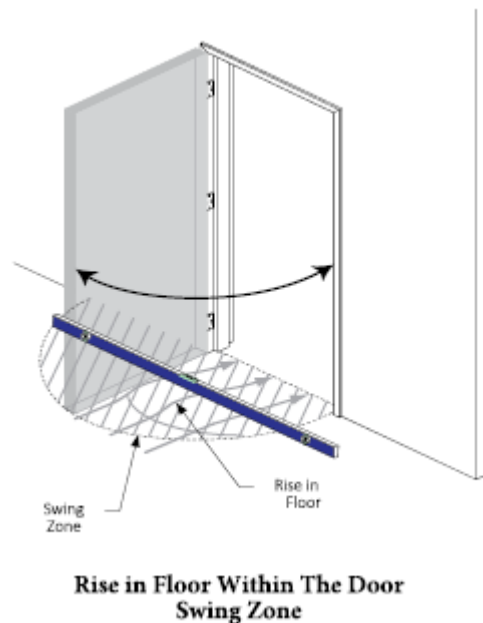
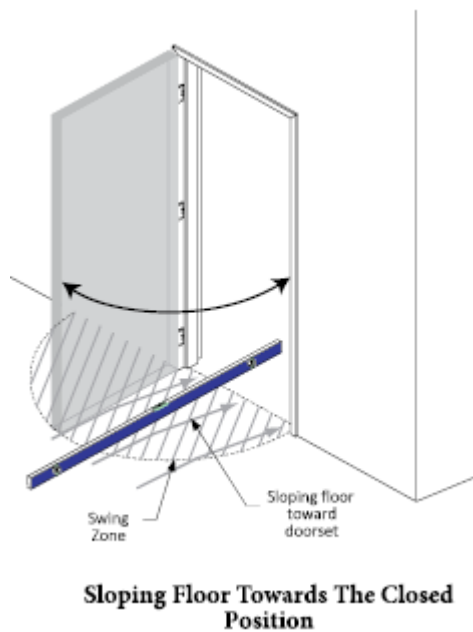

'Poor practices and carelessness could cause the fire resistance to be compromised or require costly rectification, indirectly increasing the cost of fire protection to the industry'

Wedging open a Fire Resistant Door

RESPONSIBILITIES OF OTHER TRADES

Greater attention must be paid to poor practices and carelessness that could cause the fire resistance to be compromised or require costly rectification, indirectly increasing the cost of fire protection to the industry. The wedging open of a fire door with the door closer installed will cause damage to the fire door. The damage in some cases cannot be rectified and the door will need to be replaced.

- Think about the protection of other trades works.
- Ensure everyone understands what damage could be caused.
- The cost of replacing the door will need to be paid for by YOU.

Wedged Door Leaf

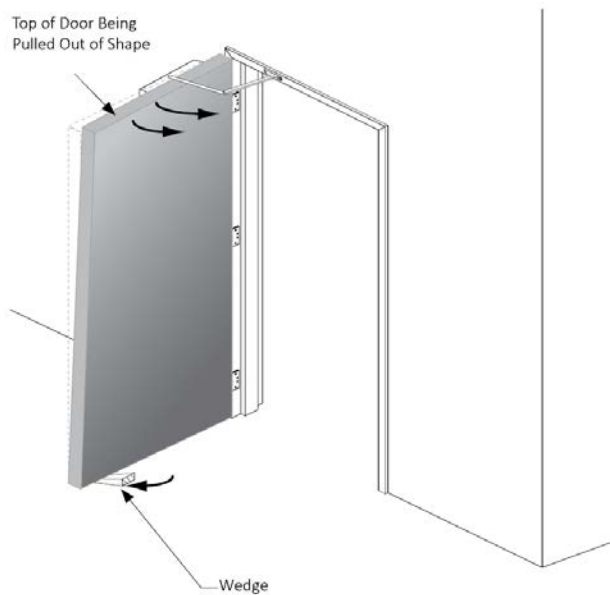

Wedge

Wedged Door Leaf

Installation Instructions

FIRE DOOR INSTALLATION

This Technical Bulletin describes the installation method to be used by door installers when installing E-Core® Fire Doors. This information is to be used as instruction for fire door installers.

PRE-INSTALLATION

1. Check that all hardware and fixings are on hand and compliant.
2. Ensure the latest revision of the door schedule is being used and the door is correct for the opening.
3. Measure your reveal height
4. and width to check if the doors will fit into the opening.
5. Check if the frame is installed correctly and its installation will not cause the fire door to be non-compliant.
6. Check hinges are well secured and there is sufficient quantity.

DOOR INSTALLATION

1. The Door Manufacturer's marking will identify the hinge and lock side (marked top hinge together with pilot hole identifier). Mark the doors on the top face hinge side. Mark 'top hinge corner'. *You can also confirm by using a magnet to locate the steel reinforcing for hinges and closer.* (Photo Example: 1.)
2. Open the hinges then place door leaf in the frame.
3. Scribe the door with a 2.5mm spacer.
4. Machine door to scribed marks and finish by planing a minimum 2mm splay or "Back edge". *Back edge will ensure the closing door edge does not bind on the door frame.* (Example: 2)
5. Use a sharp chisel or trimmer to cut the check out for the door hinges. Remove the hinges from the frame and drill/ screw them onto the door. (Refer E-Core® approved fixings).
6. Turn door end on end and plane the lock side. The lock side will require a 2mm splay or "Back edge".
7. Sand edges and paint top and bottom of the door.
8. Hang the door onto the door frame and check door swing.
9. Fit the nominated door hardware as per the manufacturers installation instructions.
- 10.
11. Installation clearances shall be as per AS1905.1.
12. Prime top and bottom of the door and under hardware.

Additional steps for pairs (doubles)

1. Repeat process for second leaf ensuring correct gap for meeting stile.
2. Fit the nominated door hardware as per the manufacturers installation instructions.
3. Ensure intumescent seals are secured into the groove within the aluminium meeting stiles.
4. Fit aluminium meeting stiles with 10 gauge self drilling screws.
5. Where required, insert and secure smoke seals to each door leaf meeting stile.

Example: 1

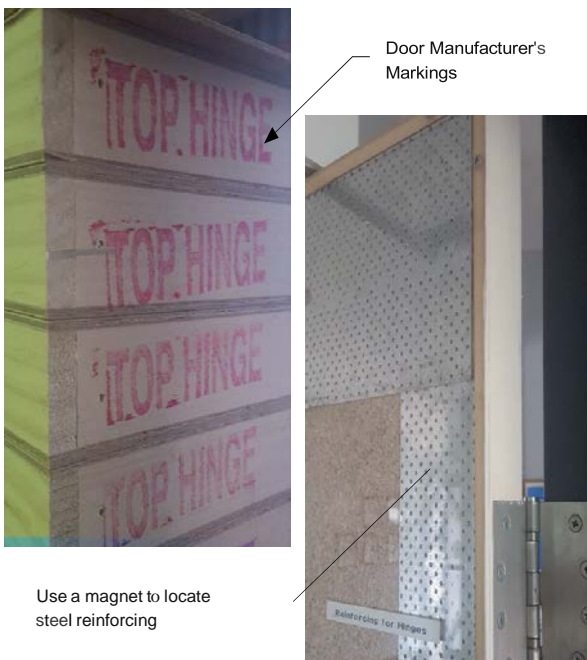

Door Manufacturer's Markings

Use a magnet to locate steel reinforcing

Hardware attachment is referenced to in: AS1905.1- Clause 5.6.1

NB: Wood screws not to be used.

NB: It is recommended to drill pilot holes.

FINAL CHECK

When the installation is complete, the fire-resistant doorset shall latch satisfactorily from the fully open position and from any intermediate position, and the closers shall demonstrate satisfactorily back checking action as required by **AS 1905.1- Clause 2.3.5.**

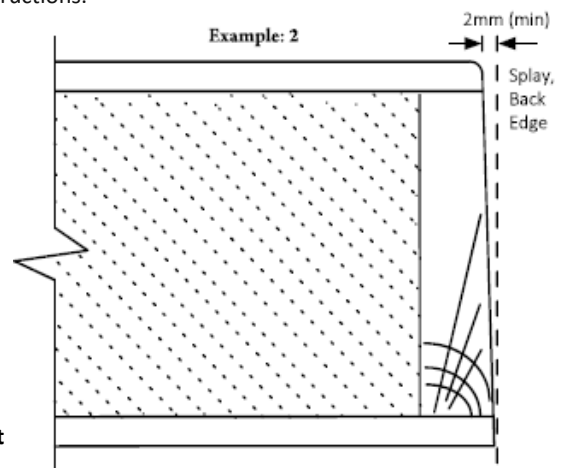

E-CORE® APPROVED FIXING (examples)

Hinges:

10 gauge x 1 1/4" (32mm) zinc plated steel or stainless steel CSK self tapping screws. (Minimum)

Door Closer:

10 gauge zinc plated steel or stainless steel pan head self tapping screws.

Clearance around door leaves

FIRE DOOR INSTALLATION

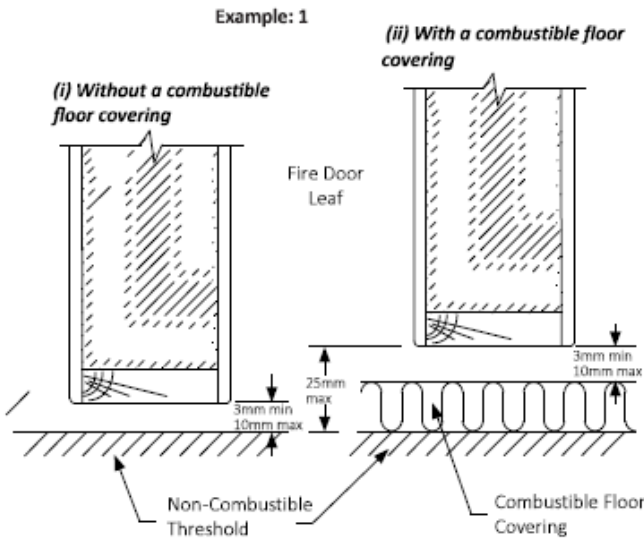

AUSTRALIAN STANDARD 1905.1:2015
SECTION 5 INSTALLATION
5.5 CLEARANCES AROUND DOORS LEAVES
Threshold and floor finish

Clearances between the bottom of all door leaves and the floor shall be as follows:

- a) Between the leaf and the top surface of the floor including any floor covering - not less than 3 mm and not more than 10 mm.
- b) Between the leaf and the top of the non-combustible threshold - not more than 25 mm.

NOTE: When the installed doorset is inspected for compliance with Item (b), the clearance should not exceed 25 mm for the purpose of certification unless a note providing information on clearances is made in the evidence of compliance.

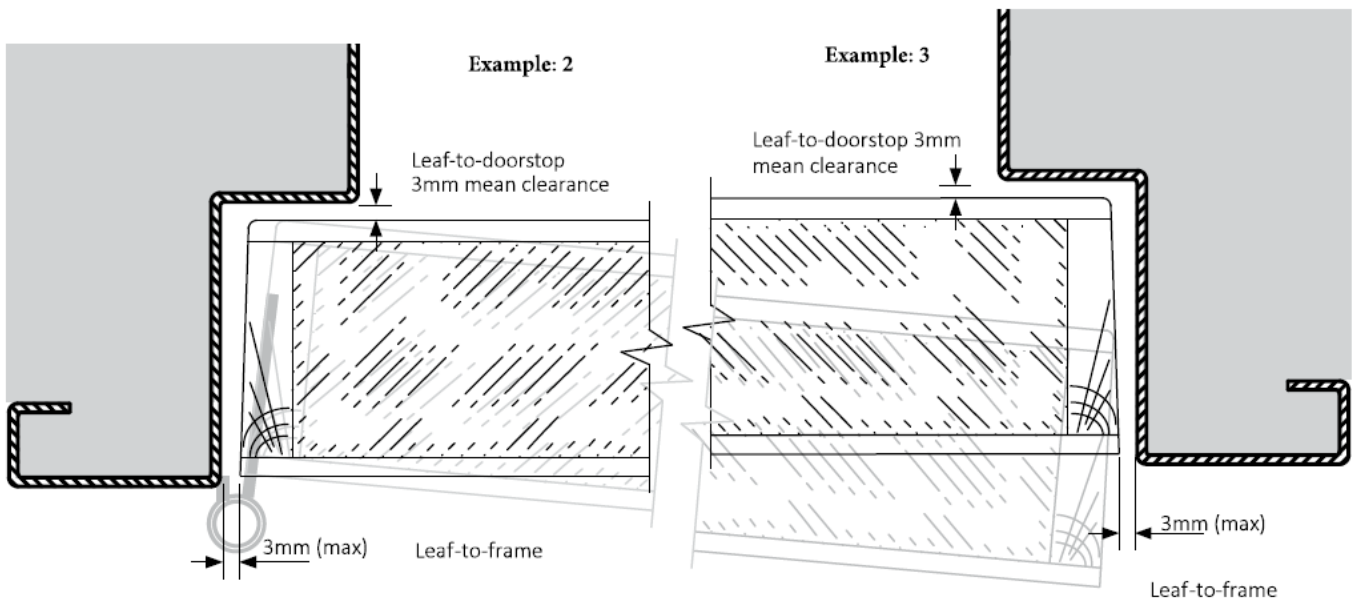

Side-hung door, leaf-to-frame

Example: 2 & 3

Door leaves side-hung into rebated frames shall be installed to swing clear of the door frame and shall have mean clearances, in the closed position, between the leaf and the head and between the leaf and each stile, of not more than 3 mm.

NOTE: Measurements should be taken at intervals of not less than 750 mm apart, and there should be a minimum of three measurements to each vertical edge of the leaf and two measurements on horizontal edge.

Side-hung door, leaf-to-doorstop

Example: 2 & 3

Door leaves side-hung into rebated frames shall be installed to swing clear of the door frame and shall have mean clearances, in the closed position, between the face of the leaf and the doorstop, not more than 3 mm, and the maximum shall be not more than 5 mm at any location.

Double-acting door sets

Clearances between the edges of the door leaf and the wall, floor, head and frame shall not exceed the clearances as tested or assessed.

Installation Instructions

DOOR STOPS

PRE INSTALLATION:

1. Check Hardware is compliant with Fire Door
2. Check that the Fire Door has enough direction of swing so that the door reaches the door stop without bottoming out on a potential impediment (E.g. Closer, Floor, Wall)
3. Nominate a position for the door stop that will work without damaging the Fire Door or become a trip hazard

INSTALLATION: FLOOR MOUNT DOOR STOP

- Check what flooring your Door Stop will be installed into

CONCRETE

1. When drilling into concrete, ensure that all workers involved in concrete drilling are equipped with appropriate PPE, including safety goggles, hearing protection, gloves, and respiratory masks.
2. Nominate a location for your Door Stop
3. Mark out the positions for your plugs to be fastened into the floor with screws
4. Use a hammer drill bit to drill into the concrete
5. Once all holes are drilled, use a vacuum to clean up remaining silica
6. Insert plugs into the holes which have been drilled
7. After the plugs have been installed line up your door stop over the plugs and fasten the Door Stop to the ground with screws
8. Test to see if Door Stop is operational with the Door and structurally fastened

TILE

1. When drilling into Tile, ensure you use a diamond core drill bit for accurate and precise cuts
2. Nominate a location for your Door Stop
3. Mark out the positions for your plugs to be fastened into the floor with screws
4. Use a diamond core drill bit with water to slowly cut through the tile
5. Once all holes are drilled, wipe up excess water and use a vacuum to clean up remaining silica
6. If needed, use a hammer drill bit to drill into the concrete if needed for extra depth in hole.
7. Insert plugs into the holes which have been drilled
8. After the plugs have been installed line up your door stop over the plugs and fasten the Door Stop to the ground with screws
9. Test to see if Door Stop is operational with the Door and structurally fastened

TIMBER

1. Recommended to use plugs when drilling into timber
2. Nominate a location for your Door Stop
3. Mark out the positions for your plugs to be fastened into the floor with screws
4. Use a timber drill bit to drill into the floor
5. If needed, use a hammer drill bit to drill into the concrete if needed for extra depth in hole.
6. Once all holes are drilled, use a vacuum to clean up remaining waste
7. Insert plugs into the holes which have been drilled
8. After the plugs have been installed line up your door stop over the plugs and fasten the Door Stop to the ground with screws
9. Test to see if Door Stop is operational with the Door and structurally fastened

VINYL/CARPET

1. Nominate a location for your Door Stop
2. Mark out the positions for your plugs to be fastened into the floor with screws
3. Use a drill bit to drill into the floor
4. If needed, use a hammer drill bit to drill into the concrete if needed for extra depth in hole.
5. Once all holes are drilled, use a vacuum to clean up remaining waste
6. Insert plugs into the holes which have been drilled
7. After the plugs have been installed line up your door stop over the plugs and fasten the Door Stop to the ground with screws
8. Test to see if Door Stop is operational with the Door and structurally fastened

Installation Instructions

INSTALLATION: WALL MOUNT DOOR STOP

CONCRETE

1. When drilling into concrete, ensure that all workers involved in concrete drilling are equipped with appropriate PPE, including safety goggles, hearing protection, gloves, and respiratory masks**
2. Nominate a location for your Door Stop
3. Mark out the positions for your plugs to be fastened into the floor with screws
4. Use a hammer drill bit to drill into the concrete
5. Once all holes are drilled, use a vacuum to clean up remaining silica
6. Insert plugs into the holes which have been drilled
7. After the plugs have been installed line up your door stop over the plugs and fasten the Door Stop to the ground with screws
8. Test to see if Door Stop is operational with the Door and structurally fastened

SKIRTING

1. Nominate a location for your Door Stop
2. Mark out the position for where your Door Stop is going to be installed
3. Use a timber drill bit to pre drill a hole for your screws
4. line up your door stop over the pre drill hole and fasten the Door Stop to the skirting board with screws
5. Test to see if Door Stop is operational with the Door and structurally fastened

INSTALLATION: DOOR MOUNT

1. Nominate a location on your door for your Door Stop
2. Mark out the position for where your Door Stop is going to be installed
3. Use a timber drill bit to pre drill a hole for your screws
4. line up your door stop over the pre drill hole and fasten the Door Stop to the Door with screws
5. Test to see if Door Stop is operational with the Door and structurally fastened.

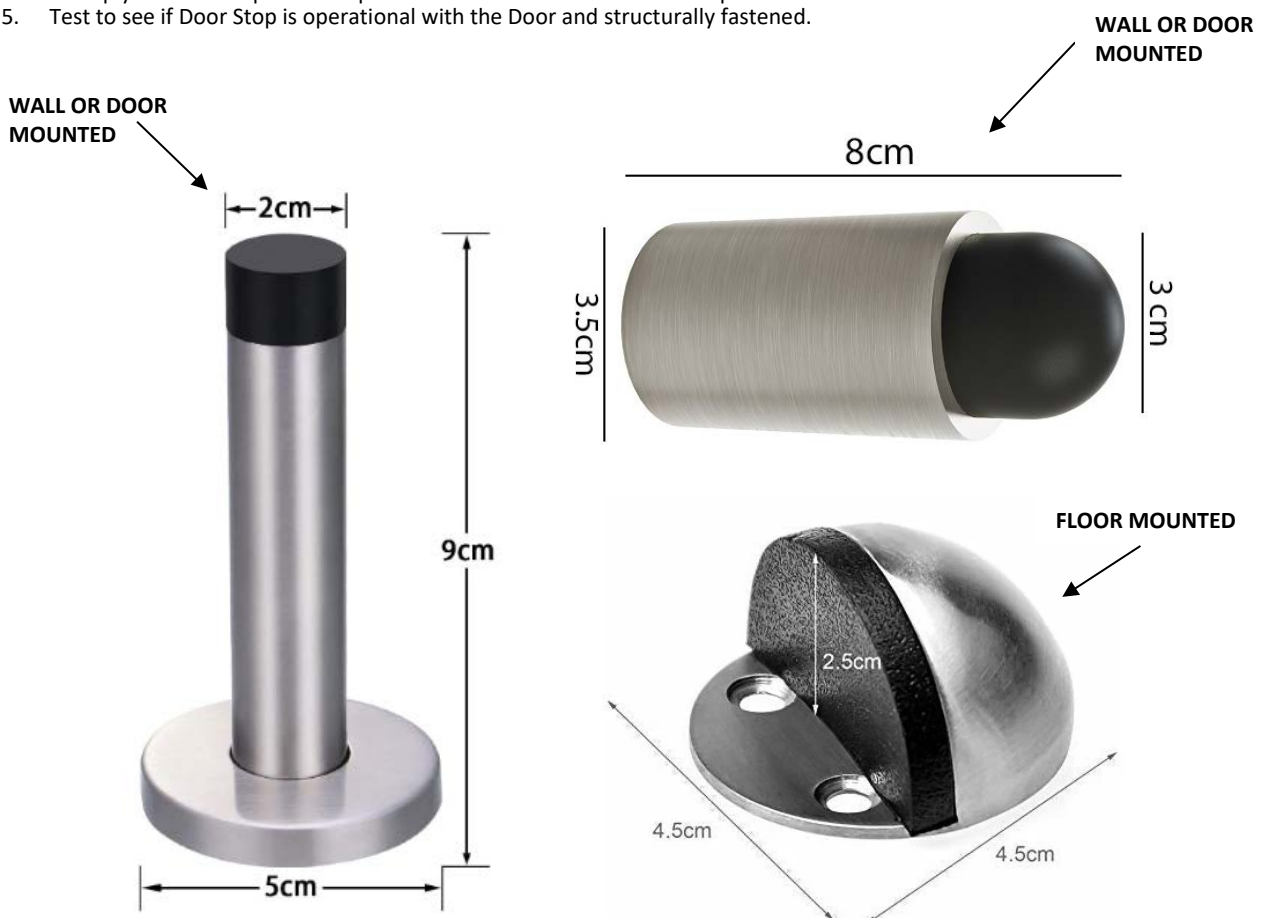

Installation & Defect Avoidance

Issue:

Lateral movement in the door frame.

Compliance consequence:

Doors when installed, will be subject to binding, closing and latching issues, due to an unstable frame that is subject to flex/pivot; and performance issues in regard to deflection that occurs in a fire event.

<i>Issue:</i>	<i>Cause:</i>	<i>Prevention:</i>
Installed frame pivots/ has movement independent of the wall	Frame is not fixed off adequately and in accordance with manufacturers or tested system requirements	<p>Ensure frame is fixed with correct mechanisms, and at correct required (maximum) centres</p> <ul style="list-style-type: none"> centres will vary between fire door core types (brands) and need to be confirmed prior to fix-off requirement for fixing-off to the (frame) head will vary between fire door core types (brands), and need to be confirmed prior to fix-off test sponsors recommendations for screw type, gauge and length of fixings, should be checked prior to fix off

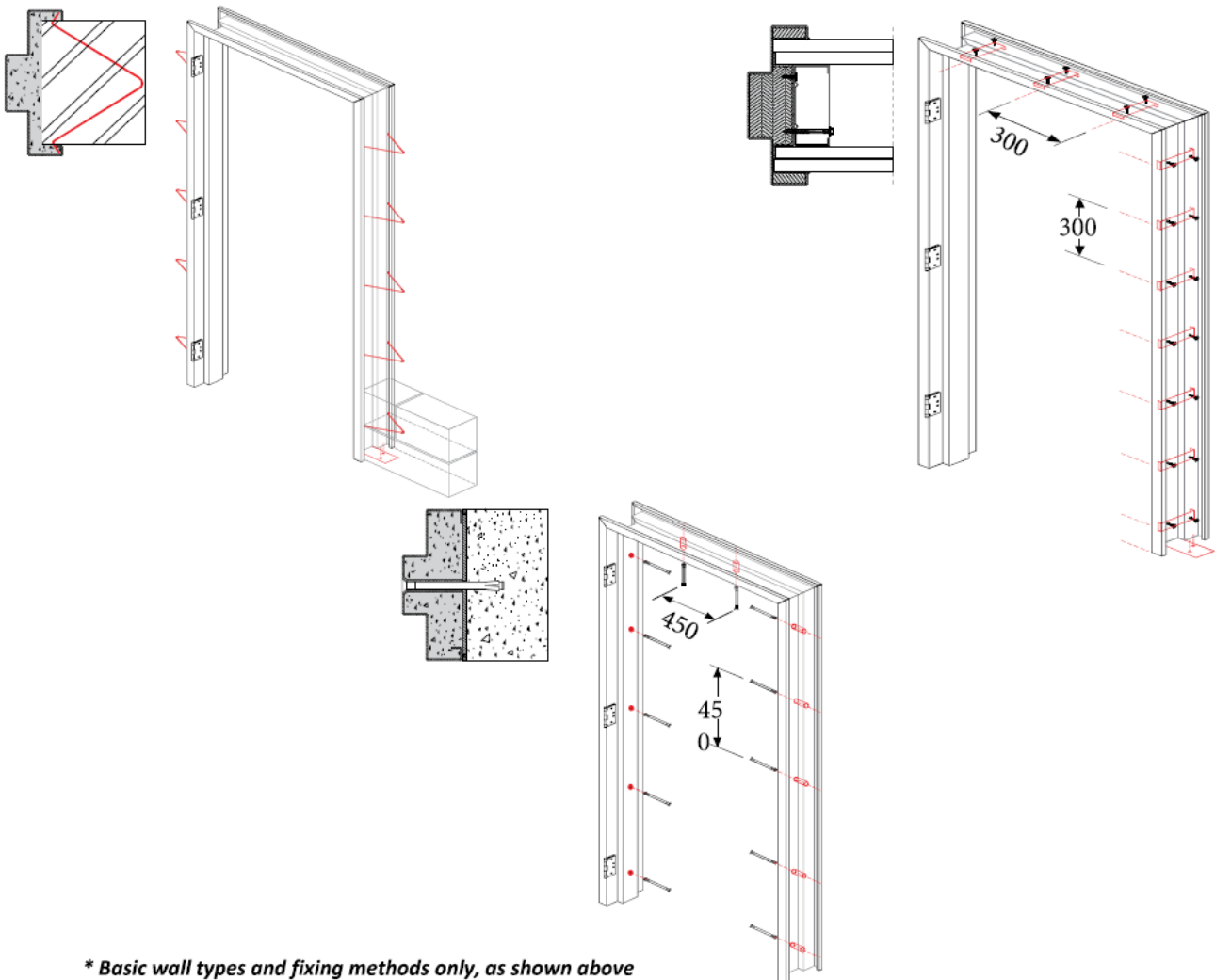

* Basic wall types and fixing methods only, as shown above

Installation & Defect Avoidance

Issue:

Doorset is not properly supported by the wall (and not consistent with tested system) *Stud Partition Walls*

Compliance Consequence:

Doorset when completely installed, will likely be subject to 'sag' over time, and importantly the doorset (at the junction between the wall and the door frame) will not resist deflection to the required limits of the tested prototype system that incorporated boxed jamb studs.

Issue:	Cause:	Prevention:
<p>Installed frame has movement and or future deflection issues, (particularly after the door is hung), due to inadequate support by the wall at the jambs.</p>	<p>Jamb studs are not boxed (ie: single stud only has been applied at the jamb opening)</p>	<p>Ensure the wall has been built with boxed studs either side of the door frame opening</p> <ul style="list-style-type: none"> • centres will vary between fire door core types (brands) and need to be confirmed prior to fix-off • requirement for fixing-off to the (frame) head will vary between fire door core types (brands), and need to be confirmed prior to fix-off • test sponsors recommendations for screw type, gauge and length of fixings, should be checked prior to fix off

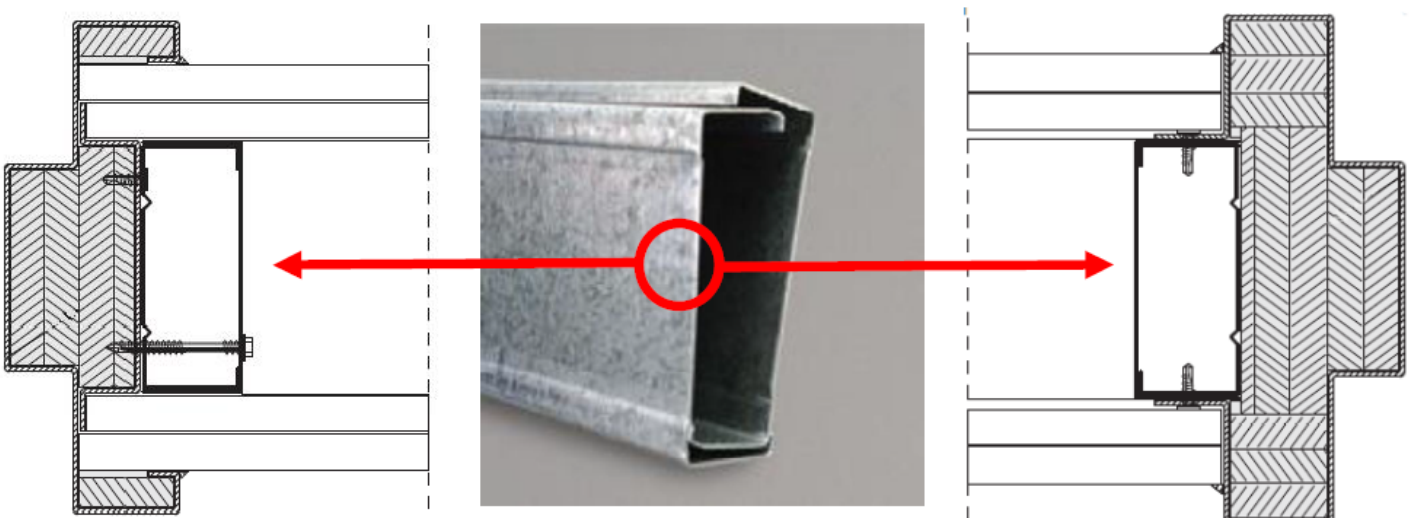

Installation & Defect Avoidance

Issue:

Door frame flexing / pivoting at the bottom.

Compliance Consequence:

Movement in the frame will translate to 'flexing' between the wall, the frame, the hinges, and the door, and will affect the operation of the doorset. This can include an opening up of the perimeter gaps beyond maximum tolerances, and result in severe deflection in a fire event (leading to the spread of fire).

Issue:	Cause:	Prevention:
<p>Installed frame has movement at the bottom of the frame, and is pulling out of wind at the bottom of the frame.</p>	<p>Frame is not secured at the bottom (both sides) to the substrate.</p>	<p>Ensure the frame is anchored on both sides (stiles) to the substrate</p> <ul style="list-style-type: none"> • <i>base plates should be present at the bottom of each stile, and should be folded out to 900 to squarely and firmly meet the substrate.</i> • <i>2 anchors per base plate will ensure proper purchase to the substrate, and ensure there is no pivoting movement in the frame.</i>

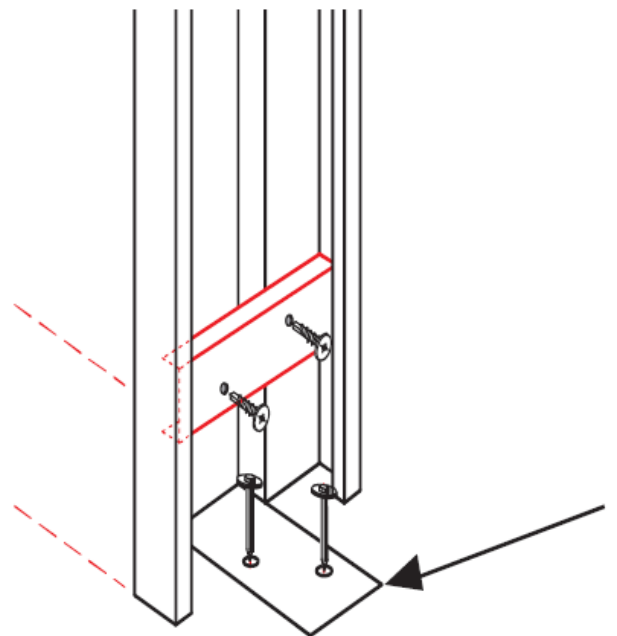

** Where the above fixing methodology is not published by particular fire door core brands, this is to be considered 'best practice' for installation, to negate potential defect*

Installation & Defect Avoidance

Issue:

Gap under the door frame (between the floor and the bottom of the frame).

Compliance Consequence:

Hot gas / heat transfer can occur via this breach in the system, which could lead to fire spread. Packers are not sufficient - the frame is required to meet, and be anchored firmly to the non-combustible substrate.

<i>Issue:</i>	<i>Cause:</i>	<i>Prevention:</i>
Installed frame has gap between the floor and the bottom of the frame.	The frame has been installed to an opening that is not square/ level at the top of the opening; or there is an inconsistency in the floor (substrate).	<p>Ensure the frame is square and level at the head - if not, then remedy by re-fixing the frame.</p> <p>Correct the floor by building up the affected area of substrate beneath and around the doorset.</p> <ul style="list-style-type: none"> • topping must be of same non-combustible material as the substrate • once cured the frame can be anchored firmly and in direct contact with the substrate

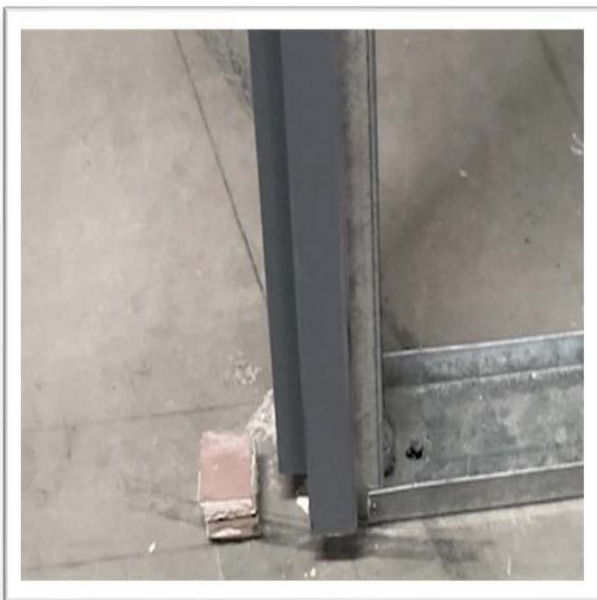

Installation & Defect Avoidance

Issue:

Frame Back-filling

Compliance Consequence:

All fire-resistant doorsets (with steel door frames) tested since incorporation of AS1530.4 2005 edition testing standard into the NCC; have been required to be inclusive of a back-filling to the steel door frame.

The back-filling then became an aspect to be checked and confirmed as a component of installation, under AS1905.1 2005.

Background:

The introduction of thermocouples, in AS1530.4 2005, to specifically measure the heat generation through the door frame, revealed that unfilled steel door frames transferred heat through the frame at a rate approx five times faster than that of a back-filled frame.

The intent of back-filling is to ensure the slowing of such heat transfer, to prevent spontaneous combustion on the non-fire side of a wall and doorset, to any combustible materials adjacent the doorset, which would further the spread of fire throughout a building.



Installation & Defect Avoidance

Issue:

The enclosed section of the door frame is not filled properly with correct filling medium.

Compliance Consequence:

Not filling the frame, or partially filling while leaving voids, equates to an installation that fails to match the tested prototype system, and is therefore non-compliant.

Issue:	Cause:	Prevention:
<p>Frame is not filled/ not filled completely</p>	<p>Inadequate volume of correct fill medium has been applied.</p>	<p>Ensure the enclosed section of the frame is completely filled, with medium appropriate to the wall type.</p> <ul style="list-style-type: none"> • <i>Frames in masonry (brick, block, concrete) walls should be filled with cementitious medium (cement; mortar; or non-shrink grout)</i> <p><i>This should be done progressively with the building in of the frame to the block / brick.</i></p> <p><i>In the case of retro-fit frames, this can be pre-filled and set prior, to ensure complete fill; or can be pumped in from the top corners of the frame (does come with risk of voids occurring).</i></p> <ul style="list-style-type: none"> • <i>Frames in partition (stud and plasterboard lined) walls, should be filled with plasterous medium (plasterboard strips; and or cast plaster).</i> <p><i>This should be done prior to installation of the frame to ensure complete fill.</i></p>

Plaster Options



Masonry Options



Installation & Defect Avoidance

Door Leaf Issue:

Bowed / Twisted Door(s)

Compliance Consequence:

Fire doors do not maintain required gap (to maximum tolerance), between the face of the door and the frame stop section - maximum of 5mm; due to door cupping away from the frame stop, either in the middle, or at top and or bottom of door.

Fire doors fitted with perimeter door seals for smoke or acoustic purposes, or smoke doors fitted with perimeter smoke seals; do not maintain flatness within tolerance, to allow the seals to engage correctly to prevent smoke leakage and or allow intended acoustic performance.

<i>Issue:</i>	<i>Cause:</i>	<i>Prevention:</i>
Bowed / Twisted Door	<ul style="list-style-type: none"> • Moisture ingress • Wedging • Temperature differential 	<p>Store doors in a protected environment.</p> <ul style="list-style-type: none"> • internal environment; not exposed to the elements or wet works. • preferably covered by plastic or tarp. <p>Store doors flat and (elevated) off the floor with pallet or gluts.</p> <ul style="list-style-type: none"> • Doors stacked against a wall can slump over extended periods. • Doors stacked against a recently built block wall or recently plastered wall can absorb moisture from the curing (drying) mortar or plaster cement (or just distort due to cold masonry). <p>Ensure doors are painted prior to installation.</p> <ul style="list-style-type: none"> • Doors should be primed as a bare minimum on arriving to site.



Installation & Defect Avoidance

Door Leaf Issue:

Bowed / Twisted Door(s)

Compliance Consequence:

Fire doors do not maintain required gap (to maximum tolerance), between the face of the door and the frame stop section - maximum of 5mm; due to door cupping away from the frame stop, either in the middle, or at top and or bottom of door.

Fire doors fitted with perimeter door seals for smoke or acoustic purposes, or smoke doors fitted with perimeter smoke seals; do not maintain flatness within tolerance, to allow the seals to engage correctly to prevent smoke leakage and or allow intended acoustic performance.

<i>Issue:</i>	<i>Cause:</i>	<i>Prevention:</i>
Fire door is binding or sticking.	Door (having been shaped square) is sticking / pressure locking against the seals on the frame.	Ensure door has been 'backed-off' from the leading edge of the door (the face that engages the frame stop section). <ul style="list-style-type: none"> a nominal 2mm back-bevel to the leading edge, all around will give clearance to alleviate binding, sticking or pressure locking.

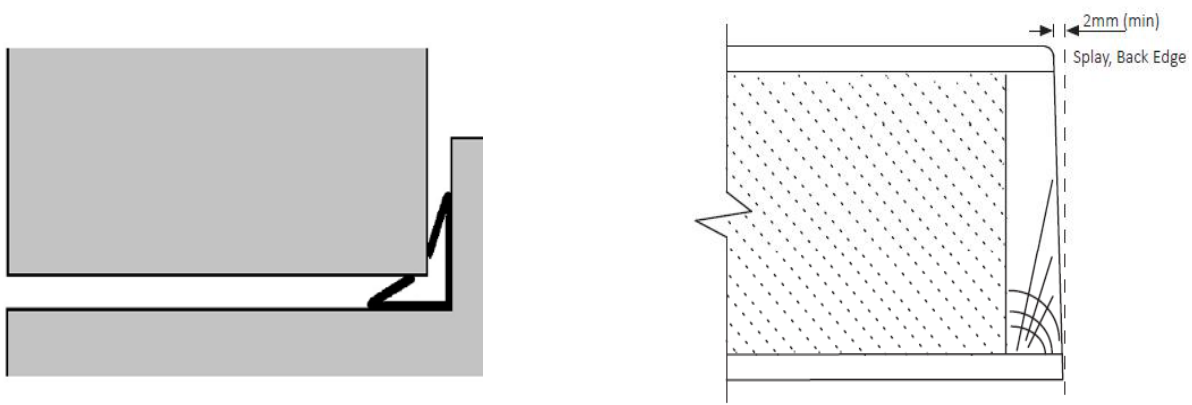

Installation & Defect Avoidance

Door Leaf Issue:

Fire (or smoke) door is not latching.

Compliance Consequence:

For fire doors, this is a critical aspect of compliance, as it is the function that ensures the barrier to resist the spread of fire from one compartment to the next.

A latched door resists the deflection that occurs during a fire - a fire source, through the consumption of oxygen, will act to pull a door toward the fire (ie: the door wants to open) and this negates the required fire-resistant barrier.

In the case of smoke doors, the same deflective behaviour of the door under stress from fire or hot smoke, will disengage the door from the perimeter seals, consequently resulting in spread of smoke.

<i>Issue:</i>	<i>Cause:</i>	<i>Prevention:</i>
Fire/ smoke door is not latching.	Lock strike is not retracting smoothly / door closer is adjusted incorrectly.	Maintain and adjust the door hardware. <ul style="list-style-type: none"> • clean and lubricate the locksets strike (tongue), or adjust the strike keeper. • locate and adjust the door closers latching function (there is a balance between latching firmly, and slamming, that this function must be set to)



Installation & Defect Avoidance - Gap Tolerances

Perimeter (top and sides) gaps - side hung (hinged) doors; leaf to frame.

Mean clearance of no more than 3mm.

The established method for determining the mean (average), is by measurements taken at no less than 750mm apart, with a minimum of 3 measurements per (vertical) stile, and minimum 2 measurements at the (horizontal) head.

The below example shows that flexibility is provided to allow for trimming tolerances.

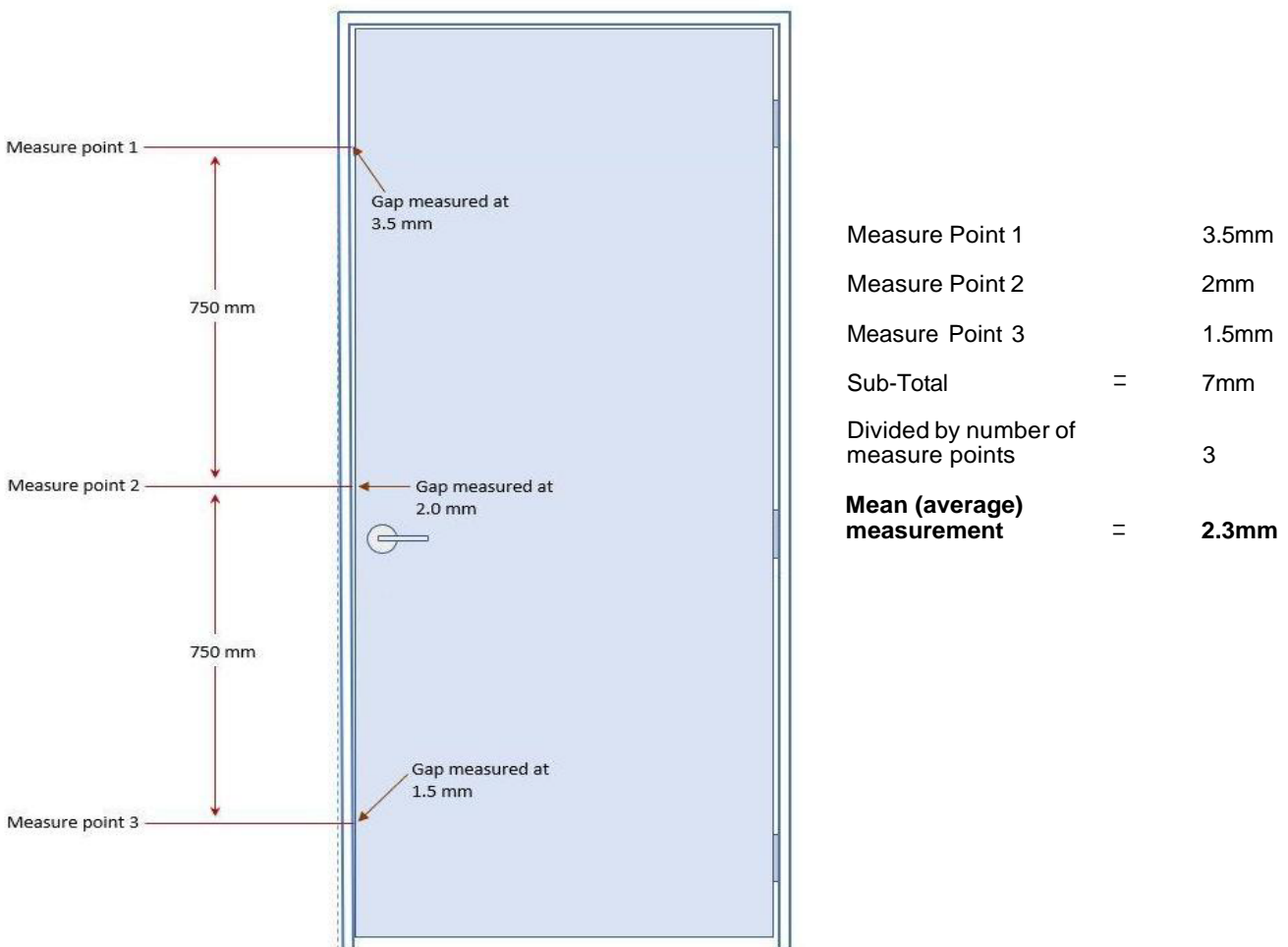

Installation & Defect Avoidance – Gap Tolerances

Threshold gaps (bottom) - side hung (hinged) doors; leaf to floor.

Consistently, a minimum of 3mm and maximum of 10mm clearance between the bottom of the door leaf and the finished floor, is required - this applies to any non-combustible substrate (eg: concrete) as the finished floor.

However, there is allowance under the standard also for combustible floor coverings (eg: carpet, vinyl, etc) as applied over the non-combustible substrate - this, as up to 25mm from the bottom of the door leaf to the non-combustible substrate, inclusive of the (minimax) gap from leaf to finished (combustible) floor covering.

Example:
 25mm
 minus (3mm - 10mm) swing clearance I finished bottom gap
 = 15mm - 22mm additional allowance for a non-combustible floor covering.

Note: not all of the 25mm extra allowance is to be factored in unless the floor covering is at the maximum 22mm thickness - only the additional required (up to max of 25mm) is to be calculated in, in direct relation to the thickness (material and adhesive) of the applied NC covering, as the max 10mm finished gap is still applicable.

Extract from AS1905.1 2015

